

Timothy J. Davis\*, Daniel E. Gómez and Ann Roberts

# Plasmonic circuits for manipulating optical information

DOI 10.1515/nanoph-2016-0131

Received July 30, 2016; revised September 16, 2016; accepted September 22, 2016

**Abstract:** Surface plasmons excited by light in metal structures provide a means for manipulating optical energy at the nanoscale. Plasmons are associated with the collective oscillations of conduction electrons in metals and play a role intermediate between photonics and electronics. As such, plasmonic devices have been created that mimic photonic waveguides as well as electrical circuits operating at optical frequencies. We review the plasmon technologies and circuits proposed, modeled, and demonstrated over the past decade that have potential applications in optical computing and optical information processing.

**Keywords:** nanorods; optical computing; optical devices; optical logic devices; optical properties of nanostructures; optical signal processing; plasmonics.

**PACS:** 73.20.Mf; 42.79.Sz; 42.79.Ta; 42.79.-e; 78.67.Qa; 78.67.-n.

## 1 Introduction

Optical information processing (optical computing) has been an active topic of research for at least six decades already [1]. In its original form, Fourier transforms of coherent light distributions were performed using lenses, enabling extremely fast and highly parallel data processing such as correlations for object recognition. There has been renewed interest in all-optical methods to process signals in communication networks [2, 3] with the idea of using optical processing elements to enable

“software-defined networks” [4, 5] necessary to simplify network reconfigurability. As data in optical communications can be encoded using amplitude, phase, intensity, wavelength, and polarization, direct serial operations between light signals can eliminate the complex optics-electronics-optics conversion, thereby maintaining the encoding during processing.

However, there are good reasons electronics is used for computation whereas optics is used for communication [6]. Electronics is based on the movement of electrons, with signals encoded using current or voltage. The operation frequency of electrical circuits is limited by the rate at which electrons can move, which in turn is governed by inductive and capacitive effects as well as resistive losses associated with electron propagation in materials. Electronic systems are capable of strong non-linear behaviors, such as switching and state changes, because of the strong interaction between electrons mediated by their electric fields. More fundamentally, electrons have mass and therefore can be confined in stationary states in small regions of space, which is important for memory. Electronic circuits are characterized by electron propagation through wires, resistance, capacitance, inductance, and non-linear behavior as represented by transistors (Figure 1).

Photonics is based on the propagation of light. Unlike electrons, the optical signal can be encoded directly on the photon wave function, such as by modulating the polarization or the phase of the beam, which takes advantage of the coherent nature of the wave. The carrier frequency of an optical electromagnetic wave is exceptionally high, in the region of hundreds of terahertz, enabling very large data transfer rates. However, photons interact very weakly with one another, if at all, so that all-optical modulation and switching are difficult to achieve [7]. With very intense beams, it is possible to drive non-linear changes in material properties, such as refractive index changes, that can be used for modulation or by using electro-optical effects whereby an electrical signal changes the optical properties of a material to modulate the light beam. Currently, information in communications networks is processed by converting the optical signal into an electronic one and

\*Corresponding author: Timothy J. Davis, School of Physics, University of Melbourne, Parkville, Victoria 3010, Australia, e-mail: timd@unimelb.edu.au

Daniel E. Gómez: School of Applied Science, RMIT University, Melbourne, Victoria 3000, Australia

Ann Roberts: School of Physics, University of Melbourne, Parkville, Victoria 3010, Australia

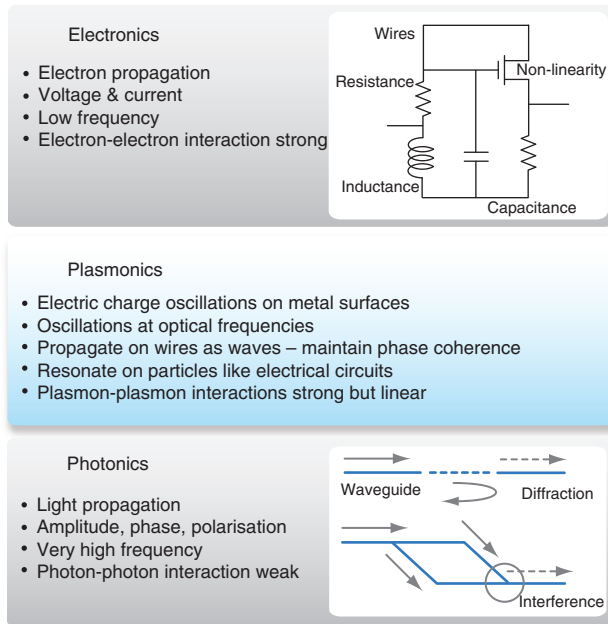

**Figure 1:** A comparison between electronic and photonic circuits. The field of plasmonics lies in between.

then applying electronic signal processing methods. This is not a coherent process, and the phase information associated with the light beam must be decoded and converted into an electrical signal. Moreover, photons have no mass and therefore cannot remain stationary in space, which is problematic for optical memory. Photonic circuits are characterized by waveguides and linear effects such as interference, diffraction, and resonance.

Intermediate between electronics and photonics lies plasmonics. Surface plasmon polaritons (SPPs), often abbreviated to plasmons, are collective oscillations of the conduction electrons driven by light at the surfaces of metals [8, 9]. As such, the plasmons oscillate at optical frequencies, around hundreds of terahertz, and are associated with strong electric fields. The plasmons maintain the phase relationships with the incident light and are therefore coherent excitations. As plasmons can be confined to regions 100 times smaller than light focused to a diffraction-limited spot [10], they provide a means to manipulate optical energy at the nanoscale. This size regime lies in between that of photonics, where device feature sizes are typically above 1000 nm, and that of electronics, for which transistor feature sizes are now approaching 10 nm. Plasmons propagating on metal structures such as plane surfaces, grooves, or wires or even confined to small metal particles [where they are known as localized surface plasmons (LSPs)] have been described as light on a wire [11].

It is fair to say that very little has been done using plasmonics for optical computing or optical information

processing. To date, most of the effort has been directed to understanding the basic principles and demonstrating devices in proof-of-principle experiments. The resurgence in the study of surface plasmons has been driven by the optics community, and as such, most applications of plasmonics mimic configurations in optics or photonics, such as waveguides, devices for converting polarization, optical filters, and so on [12]. However, plasmons represent the extreme frequency limit of the classical skin effect well known in radio frequency engineering, which has led to descriptions of plasmons in terms of electric circuits, antennas, and electrical filters.

In this review, we examine the optical and electrical circuit descriptions of plasmonics and then present some recent ideas on plasmonic systems that may have applications in optical-domain information processing.

## 2 A brief overview of surface plasmons

Research into SPPs has burgeoned in the last 16 years, driven largely by the emergence of methods for nanoscale structuring of metals [13–20]. Although strictly a quantum quasi-particle composed of coherent charge oscillations, plasmons can be described classically using Maxwell's equations of electromagnetism, which predicts the presence of propagating electromagnetic waves trapped at the interface between a dielectric and a metal (Figure 2). These are SPPs. They are the combined effect of the electron plasma at the metal surface coupled to the polarization charges induced in the dielectric. Light with a free-space wavenumber  $k_0 = \omega/c$  will create surface plasmons with a wavenumber  $k_{\text{spp}} = k_0 \sqrt{\epsilon_m \epsilon_d / (\epsilon_m + \epsilon_d)}$ , which depends on the relative electric permittivity of the metal  $\epsilon_m(\omega)$  and that of the adjacent dielectric  $\epsilon_d$ . At optical frequencies,  $\epsilon_m < 0$  is negative and large  $|\epsilon_m| \gg \epsilon_d$  so that  $k_{\text{spp}} > k_0 \sqrt{\epsilon_d}$ . This means that the plasmon wavelength is smaller than that of the light and the plasmon is unable to radiate into the dielectric, becoming trapped at the surface (Figure 2A and B). Furthermore, it is then quite difficult to excite surface plasmons as light from the dielectric cannot be phase-matched to it. However, plasmons radiate at discontinuities such as ridges or pits in the surface or abrupt changes in the dielectric, and likewise, light incident on these discontinuities can excite surface plasmons (Figure 2C). These discontinuities can also reflect and scatter plasmons [20, 21].

A thick metal film with dielectric materials adjacent to both surfaces will support two independent plasmon

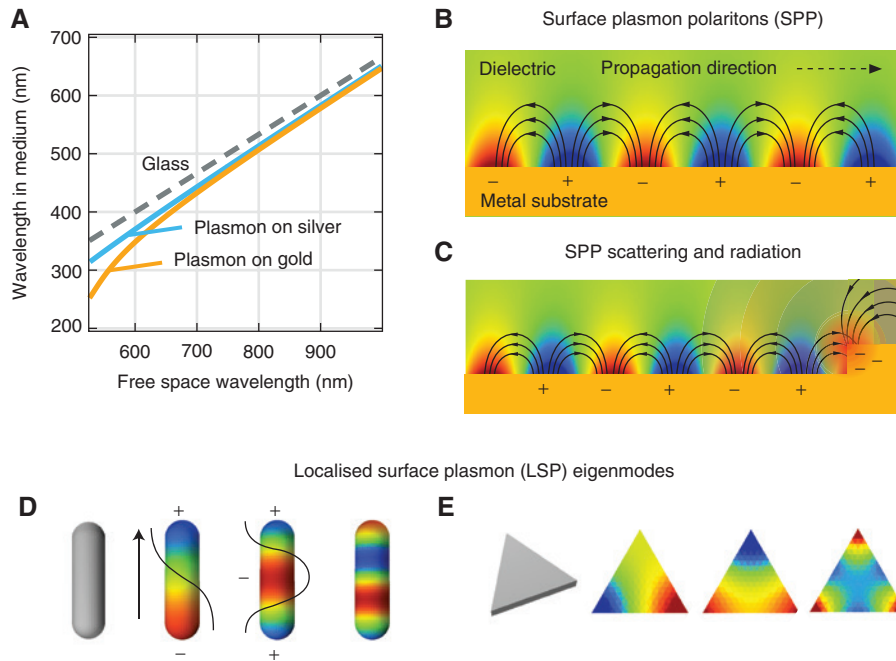

**Figure 2:** Plasmons propagating on surfaces: (A) The wavelength of an SPP is shorter than the free space wavelength of light or the wavelength within the dielectric, which prevents the plasmon from radiating; (B) the electric field associated with an SPP propagating over the surface of a thick metal film; (C) illustration of a plasmon scattering at a discontinuity with some energy converted to radiation in the dielectric; (D–E) examples of LSPs on different metal particles. These show the charge distributions (blue positive, red negative) of different resonant modes. The fundamental mode is a half wavelength with a strong dipole moment.

waves, one for each surface, with wavelengths depending on the permittivities of the dielectrics. If the metal film becomes thinner than the skin depth of the electromagnetic wave, the plasmon electric fields penetrate the full thickness of the film leading to coupled modes and mode splitting [22]. For such thin films, it is possible to excite surface plasmons using special geometries (Kretschmann, Otto) and appropriately chosen dielectrics [8, 9].

As plasmons propagate as waves, they can reflect, scatter, diffract, and interfere, which enables them to be used in much the same way that light is used in photonics. At certain frequencies, plasmons excited on the surfaces of metal particles exist as standing waves (Figure 2D and E), which are known as LSPs. The characteristic frequencies correspond to LSP resonances [23] and are associated with a large number of possible standing wave modes [24]. As these particles are generally much smaller than the wavelength of light, with dimensions typically between 10 nm and 200 nm, no phase-matching condition is necessary and LSPs can be excited simply by shining light on the particles at an appropriate frequency, but only those modes that have non-zero electric dipole moment are excited, the other modes, appearing “dark”. Because of losses in the metal (essentially Ohmic losses), the

resonances are much broader than those usually found in spectroscopy on atoms and molecules, with quality factors around  $Q \sim 10$  (for example, see Figure 6A). Metals such as aluminum, gold, and silver are commonly used in plasmonics because of their relatively low loss at optical frequencies.

In the following sections, we will discuss different devices created using surface plasmons. Most of these devices have been used for proof-of-principle demonstrations and may not be practical in real applications. We begin by examining research into devices based on plasmon waveguides that use the wave-like properties of plasmons propagating over surfaces or within special guides to demonstrate both linear and non-linear optical devices for manipulating light at the nanoscale. As plasmon emission and detection is important, we briefly present some research into plasmon emitters and detectors as well as coupling to fluorescent materials. We then examine plasmonics from the point of view of electronics and review research on LSPs that mimic inductor-capacitor circuits operating at optical frequencies. Within this topic, we consider optical antennas, optical circuits, and concepts for performing mathematical operations on light fields. A brief mention of quantum plasmonics follows. Finally, because of the losses encountered with metals,

there has been work towards low loss materials supporting surface plasmon propagation.

### 3 Plasmonic waveguide circuits

Surface plasmons can propagate as waves over metal surfaces, and because plasmon wavelengths can be much smaller than light at the same frequency, they have potential in highly compact optical devices. The optical properties of these waves on surfaces have been studied [20] and applied to simple optical elements. For example, it was shown that a converging lens for surface plasmons can be created by slits cut into the metal film, which performs an optical Fourier transform analogously to macroscopic lenses, enabling traditional optical computing on-chip [25]. One of the issues with “free” plasmon propagation over surfaces is creating the plasmon in the first place. One solution is to etch a slot through the metal film to the transparent substrate. When the slot is illuminated through the substrate, the electric field penetrates to the top surface, launching plasmon waves that propagate in either direction away from the normal to the slot edge. By including slot reflectors in the surface, it is possible to interfere the plasmon waves enabling devices such as binary encoders [26], logic discriminators [27], and multiplexers [28]. Similarly, arrays of holes can be used to launch plasmons and to convert the energy back into freely propagating light [29].

Plasmon waves can be confined and guided by a thin metal strip. The motivation for such work is based on the idea that light can form high-speed and low-loss interconnects for electronic circuits and the use of plasmons enables very compact devices, an order of magnitude or smaller than the wavelength of light [14, 15, 17, 30–32]. Similar to light travelling in optical waveguides, the plasmons propagate with one or more different modes on the metal strip, depending on the strip geometry and the electric permittivities of the metal and the surrounding medium. A systematic study of the propagation in these guides [33–35] demonstrated the existence of a short-range and a long-range mode. The short-range mode is lossy because there is strong penetration of the plasmon electric field into the metal, creating electrical currents that lose energy by Ohmic resistance. The long-range mode has the plasmon electric field predominantly in the dielectric region about the waveguide, thereby reducing losses. Transmission of optical signals by plasmons in strip waveguides has been demonstrated at telecom wavelengths with data rates of 10 Gbs [36]. There have

also been investigations of plasmon propagation in more complicated multi-layer guides [22, 37] as well as arrays of particles [38–41].

As loss is a big problem with plasmon propagation in metals, there have been many studies looking for configurations of metals and dielectrics that minimize the penetration of the electric field into the metal [18]. These include grooves, slots, metal-insulator-metal designs, and so on (see Figure 3 with typical parameters in Table 1). Important factors in plasmon waveguides are the propagation distance, operating wavelength, and mode area. The propagation distance is limited by absorption, which is problematic in complex plasmonic circuits. The mode area describes the cross sectional area of the region containing the optical energy. Large mode areas reduce the ability to create compact devices. For example, subwavelength plasmon-polariton guiding by triangular metal wedges has been demonstrated [42] with propagation lengths  $\sim 120 \mu\text{m}$  and mode widths  $\sim 3 \mu\text{m}$ . Other proposed strategies to mitigate Ohmic losses in plasmon oscillation and propagation include the interaction of plasmons with gain media [43–47].

Metal-insulator-metal (MIM), sometimes referred to as metal-dielectric-metal (MDM), and gap plasmon polariton (GPP) waveguides have the advantage of simple

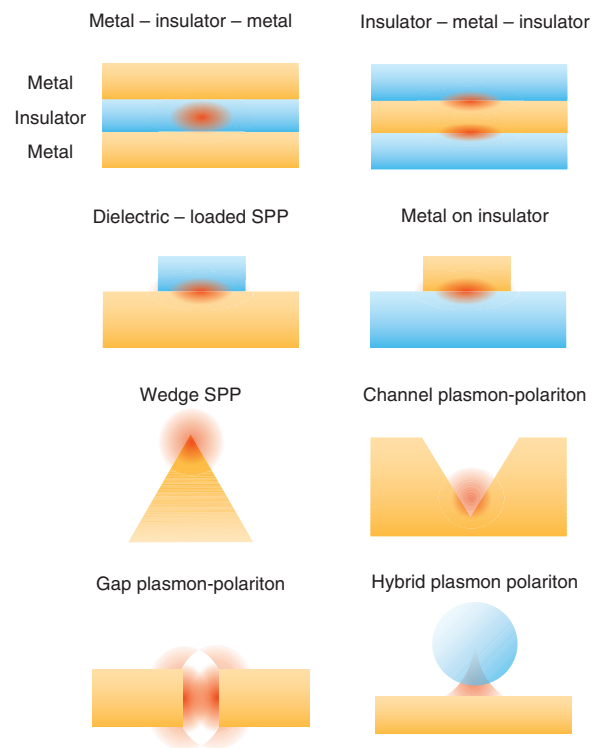

**Figure 3:** Cross sections of different types of plasmon waveguides (adapted from Ref. [18]).

**Table 1:** Comparison of plasmon waveguide optical confinement (mode area), propagation length  $L$  and free space wavelength  $\lambda$  (from Ref. [18]).

Waveguide type	Mode width/ $\lambda$	Mode height/ $\lambda$	Mode area/ $(\lambda/2)^2$	$L/\lambda$	$\lambda$ (nm)
GPP	0.13	0.13	7%	13	1550
Wedge	$\sim 0.47$	N.A.	N.A.	2	633
MIM	0.5	0.2	10%	5	685
IMI	0.19	$\sim 0.19$	$\sim 14\%$	14	1550
V-groove	0.65	$> 0.84$	$> 200\%$	$\sim 52$	1550
DL-SPP	0.62	N.A.	N.A.	10	800
DL-SPP	N.A.	N.A.	3%	4	1550
	0.04	0.04	0.6%	21	1550
	0.14	0.04	2%	N.A.	1427
HPP	0.31	0.06	7%	21	808
	0.09	0.08	3%	11	633
	0.15 <sub>theory</sub>	0.05 <sub>theory</sub>	3%	24	1310

N.A., not available.

fabrication in that they can be constructed by cutting a slot in a metal film and filling the slot with a dielectric [31, 48]. Likewise, dielectric loaded plasmon waveguides only require patterning of a dielectric layer on top of a metal film, which can be done directly using lithographic resist such as PMMA. Guiding in “V”-shaped grooves in metals has been demonstrated along with typical waveguide elements [17, 30] such as splitters and ring resonators. A theoretical analysis of plasmons in channels showed that increasing wavelength caused the fundamental mode to shift from the bottom of the channel and become more like wedge plasmons, being guided by the upper edges [49]. The plasmons guided by wedges at telecom wavelengths are better confined (smaller mode area) without increasing loss [50].

The choice of one waveguide geometry over another depends on the application. If long propagation distance is required, then one might choose a V-groove or hybrid plasmon-polariton geometry, or if small mode area is necessary, then an insulator-metal-insulator design may be preferred. However, these waveguides may not be compatible with the overall microfabrication process, in which case some trade-off will be required.

### 3.1 Emitters and detectors for integrated plasmonics

With the development of plasmon waveguide devices, there has been some research into methods of launching plasmons directly on-chip. Most of these works have been proof-of-principle demonstrations of devices with potential for integration in plasmonic circuits, but they are significantly less advanced than corresponding

devices used in photonics. In one example, a nanoscale light emitting diode with a subwavelength footprint directed some of its emission into a single-mode slot plasmon waveguide [51]. Additionally, the prospect of stimulated emission of plasmon radiation has been studied [19, 43, 52] and a device was fabricated and demonstrated [53]. This nanoscale plasmon emitter was constructed from 44-nm-sized nanoparticles with a gold core and a dye-doped silica shell. Surface plasmon oscillations were outcoupled to photonic modes at a wavelength of 531 nm. At the quantum limit, there have been experimental demonstrations of the excitation of surface plasmons by single photon emitters. Importantly, these experiments reveal that the radiative decay of a plasmon excited by a single photon also yields a single photon, even though a surface plasmon is a collective phenomenon consisting of the in-phase oscillations of a large number of electrons [54–58].

Active plasmonic devices including those with gain have been reviewed elsewhere [59]. Gain media consist of materials with electronic states that can be optically excited and subsequently de-excited in phase by another light beam, as occurs in solid-state lasers. Plasmon gain requires the gain media to emit in phase with the propagating plasmon. Amplified spontaneous emission from a polymer waveguide film containing laser dye molecules excited by surface plasmons and pumped by another laser has been observed [60], and there has been a demonstration of plasmonic propagation with net positive gain provided by an optically pumped layer of fluorescent polymer in a dielectric-metal-dielectric waveguide [61]. Incoherent plasmonic gain has been predicted with three-level fluorescent semiconductor nanocrystals in the presence of another semiconductor with negative electric permittivity

[62]. Spontaneous emission from nanosized particles and plasmon resonators has been studied theoretically [63].

Plasmon detectors have also been integrated into devices, such as a Schottky contact device with an asymmetric metal stripe waveguide [64]. Superconducting plasmon detectors were used to detect single plasmon quanta in a quantum interference experiment [65]. Plasmonic components have been used in detectors to alter the responsivity in the mid-infrared [66] as well as in the visible region [67]. In principle, such detectors can be as sensitive as those used in photonics, which is determined largely by the quality of the semiconductor photo-diode fabrication process.

### 3.2 Linear devices for optical computing

Linear devices based on waveguides tend to mimic those used in photonics. Linear devices use plasmon wave properties such as constructive and destructive interference to perform addition and subtraction operations, respectively. Moreover, plasmon excitation relies on the correct alignment of the incident electric field with respect to the ridges or grooves that launch the plasmons, as the field is required to induce a surface charge. In other words, such launching methods are sensitive to the incident polarization, which provides a means for polarization sensitivity.

Examples of photonic devices created for plasmons are shown in Figure 4 and include “Y” junctions for combining or separating plasmons [68–72], “X” junctions [70], proximity couplers [73], directional couplers [74], Mach-Zehnder interferometers for interfering plasmons

[73, 75–78], Bragg grating filters [69, 79], add-drop filters [80], and ring resonators [69, 79, 81] that transmit or reflect plasmon waves depending on frequency and switching using phase shifts [82]. A novel plasmon filter was created using two wires of different materials joined together that provided a large electric permittivity mismatch resulting in unidirectional propagation [83].

Additive logic operations have been proposed and modeled with such circuits or their variants [84–90]. There have been demonstrations of logic functions such as a NOR gate built from OR and NOT gates [91]; XNOT, XOR, and NOT gates using an air slot etched in gold on silicon dioxide [92] and an XOR gate [93]; an OR gate [94]; a logic comparator [95]; NOT, AND, OR, XOR [96]; a half-adder [97]; demultiplexers [28]; binary encoders [26, 98]; and discriminators [27]. The operations of these gates depend on phase shifts or on frequency (wavelength) differences, which presuppose specific encoding schemes for the digital information. These devices have been used to demonstrate logic operations, but there has been no concerted attempt at fulfilling the requirements of logical optical processes as required in communications networks or optical computing.

More complex arrangements are possible leading to coupling between waveguide modes [22]. Such coupling can be used to create highly compact waveguide interferometers, such as the Mach-Zehnder [77, 78, 99]. As interferometers are very sensitive to phase shifts, they have applications where non-linear effects can be used to modulate the plasmon phase.

### 3.3 Non-linear devices for optical computing

Linear devices have limited use in many photonic circuits, as they cannot demonstrate bistability or static behavior but require a continuous propagation of plasmon waves to operate (such as required for interference). While plasmon-plasmon interactions and plasmon-material interactions are generally linear, the plasmons have electric field strengths one or more orders of magnitude larger than the light wave electric fields that excite them, which makes it easier to induce non-linear behaviors in materials, enhancing modulation [100]. The non-linearities generally change the local electric permittivity that shifts the phase of propagating plasmons. When combined with plasmon interferometers, these can be quite effective modulators. In addition, it is possible to use electrical signals to induce material changes, particularly in semiconductors where the electron density, and therefore the “metallic” properties, can be altered. These are termed “active plasmonic”

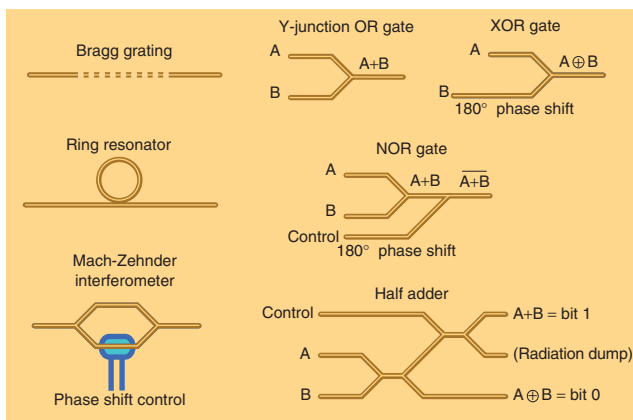

**Figure 4:** Plasmonic waveguide devices for performing optical processing. The logic circuits operate using phase shifts and interference.

devices [101]. The methods for non-linear modulation of plasmons are summarized in Figure 5.

There have been many devices proposed and simulated, such as modulation based on an external electrical signal interacting with graphene to create NOR/AND, NAND/OR, XNOR/XOR gates [102]; third-order non-linear optical materials in which the electric field intensity  $|E|^2$  of the plasmon induces refractive index changes, also known as Kerr-nonlinearity [103–107]; intense optical pulses to induce refractive index changes in GaAsInP [108]; polarization sensitive four-wave mixing non-linearity coupled to a plasmon ring resonator [109, 110]; metal-dielectric cavities filled with non-linear materials to create bistability [111] or switching [112]; a three-level system showing gain [62]; beam steering by modulating refractive index [113, 114]; electro-active materials to shift refractive index [115, 116]; and change in resonance by changing refractive index [117] or by changing material properties by electron excitation pumped by light [118, 119] (changes absorption properties within a waveband). One novel device modulated

a plasmon wave on a diffraction grating by changing the refractive index of a surface layer of fluid [120].

It is one thing to propose a device but much more difficult to fabricate and demonstrate one. Plasmonic devices based on non-linear effects can be classified into several different categories: those where the plasmon does the modulation, those where an external light signal does the modulation, and those where an external electrical signal does the modulation. These methods are summarized in Figure 5.

### 3.3.1 Direct plasmon modulation

Surprisingly, there have been few experiments demonstrating plasmon-plasmon modulation. As the plasmon is associated with a strong electric field, a propagating plasmon wave can directly induce enough refractive index change in a material to affect the phase of another plasmon. Nevertheless, the Kerr non-linearity



Modulation type	Control signal	Physical process	Rate
<p>Modulation of metal permittivity</p> 	<p>Light pulse</p> 	<p><b>Change in metal permittivity</b> Broadband signals &gt;10 THz High intensity pulses required</p>	<p>Fast modulation &lt;100 fs</p>
<p>Modulation of background dielectric</p> 	<p>Plasmon</p> 	<p><b>Non-linear glass</b> Broadband signals &gt;10 THz High intensity fields required</p> <p><b>Phase-change material</b> Broadband signals &gt;10 THz Low intensity fields required</p> <p><b>Resonant molecules</b> Narrowband signals Low intensity fields required</p>	<p>Fast modulation &lt;ps</p> <p>Slow switching &gt;μs</p> <p>Fast switching &lt;ps (depends on FWHM)</p>
	<p>Light pulse</p> 	<p><b>Non-linear glass</b> Broadband signals &gt;10 THz High intensity fields required</p> <p><b>Phase-change/photo refractive</b> Broadband signals &gt;10 THz Low intensity fields required</p>	<p>Fast modulation &lt;ps</p> <p>Slow modulation &gt;μs</p>
	<p>Electric field</p> 	<p><b>Electro-optic material</b> Broadband signals &gt;100 THz</p> <p><b>Electro-thermo-optic/ Electric-induced phase change</b> Broadband signals &gt;10 THz</p> <p><b>Semiconductor charging</b> Broadband signals &gt;10 THz</p>	<p>Switching 10 ps to s (depends on material)</p> <p>Slow modulation &gt;μs</p> <p>&lt;10 ns to &gt; 1 μs (limited by capacitance)</p>

Figure 5: Comparison of plasmon modulation methods.

of most optical materials, which determines the change in refractive index with optical intensity, is in the order of  $\sim 10^{-17} \text{ m}^2/\text{W}$  [121]. That is, to change the refractive index by 1% requires light or plasmon intensities around  $10^{15} \text{ W/m}^2$ . While this is very large, compressing a 1-W laser beam with a cross section area of  $1 \text{ mm}^2$  into a region  $30 \times 30 \text{ nm}^2$  will create such an intensity. A more practical method for modulating one plasmon by another has been demonstrated using semiconductor nanoparticles, which have an electronic excited state near the plasmon frequency. The excitation of an electron into this state by one plasmon changes the absorption and refractive properties experienced by another plasmon at a different frequency, leading to all-plasmon modulation [122, 123]. An alternative is to use a photochromic dye in which the refractive index is altered by the presence of the plasmon [124] although such processes are slow, taking milliseconds or even seconds to occur.

### 3.3.2 Modulation by external light

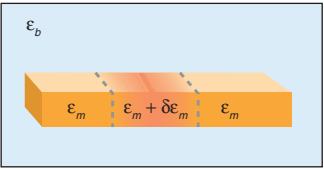
It is well known that light can induce non-linear changes in material properties, which in turn can be used to modify the phase or absorption of propagating electromagnetic waves. In one class of devices, a high intensity light pulse directed onto a metal disturbs the free electron distribution changing the electric permittivity of the metal or an adjacent semiconductor. This is an extremely fast effect, usually induced by femtosecond laser pulses, which perturbs the plasmon [125–128]. A similar effect was observed recently in indium tin oxide nanorods supporting plasmons in the infrared [129]. There are interferometers in which refractive index modulation by a light pulse on a photo-refractive material induces a phase shift in one beam path changing the interference state and therefore the plasmon intensity [130–133]. This method can be used with magneto-optical materials [134]. Light pulses can induce phase transitions in materials, such as vanadium dioxide, which are accompanied by large refractive index changes [135], or light can induce mechanical strain to change the periodicity of a grating, thereby modulating the propagating plasmon [136]. A variant on this method was to use a light pulse to induce scattering centers by the local decomposition of silver oxide [137].

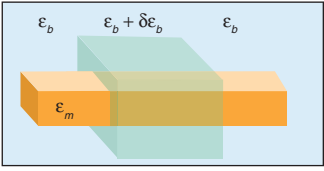
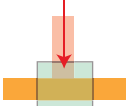
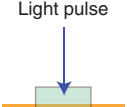
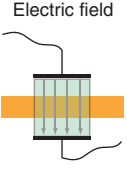
### 3.3.3 Modulation by an electrical signal

A plasmon ring resonator was constructed with a dielectric host-matrix doped with an electro-optic material that

changes refractive index on application of an electrical signal, modulating the plasmon transmission. Such devices can be slow depending on the electrical response time of the material [138]. Recently, a plasmonic Mach-Zehnder modulator was demonstrated, which used an electro-optic material to modulate the phase. The on-chip modulator was integrated into a silicon waveguide of  $10\text{-}\mu\text{m}$  length with a frequency response up to 70 GHz [139]. A novel plasmon memory device was based on memristor technology in which the growth of a metal filament under action of an applied electric field modulates the plasmon propagation [140] in a MIM waveguide structure. It is possible to control the electron density by an electric field [141–144] by using a semiconductor or electro-optic material, which can be used to modulate plasmons, or by using Tamm-plasmon-polaritons, which are plasmon states formed at the boundary between a metal and a dielectric Bragg mirror [145]. A similar phenomenon is the Faraday effect in which a static magnetic field applied to a magneto-optic material alters the optical properties, which can be coupled to plasmonic devices [146].

Variants of this method use electrical signals to induce temperature changes that modify the refractive index of a thermo-optic dielectric, again by using interferometry to alter the plasmon intensity [147] or by using electrochemical switching of material properties [148, 149].

It is clear that the most promising methods for plasmon modulation use electrical effects. These are easily integrated into existing electronic circuit designs and can show superior performance [139].

## 4 Plasmonics as electronics at light frequencies

So far, we have reviewed plasmonics technologies derived from photonics based on waveguide devices such as “Y” junctions, Mach-Zehnder interferometers, and ring resonators. These exploit the wave-like properties of plasmons propagating on surfaces. However, as we discussed in the introduction, it is possible to excite surface plasmons on small metal particles. When illuminated at a specific frequency, LSP resonances are excited (Figure 6A). Physically, these are oscillations of the conduction electrons at the surface of the particle. If we consider these oscillations from the point of view of electrical engineering, we would describe them in terms of traditional circuit elements, such as inductance, capacitance, and resistance.

A correspondence between electrical circuit elements and metal and dielectric particles was given by



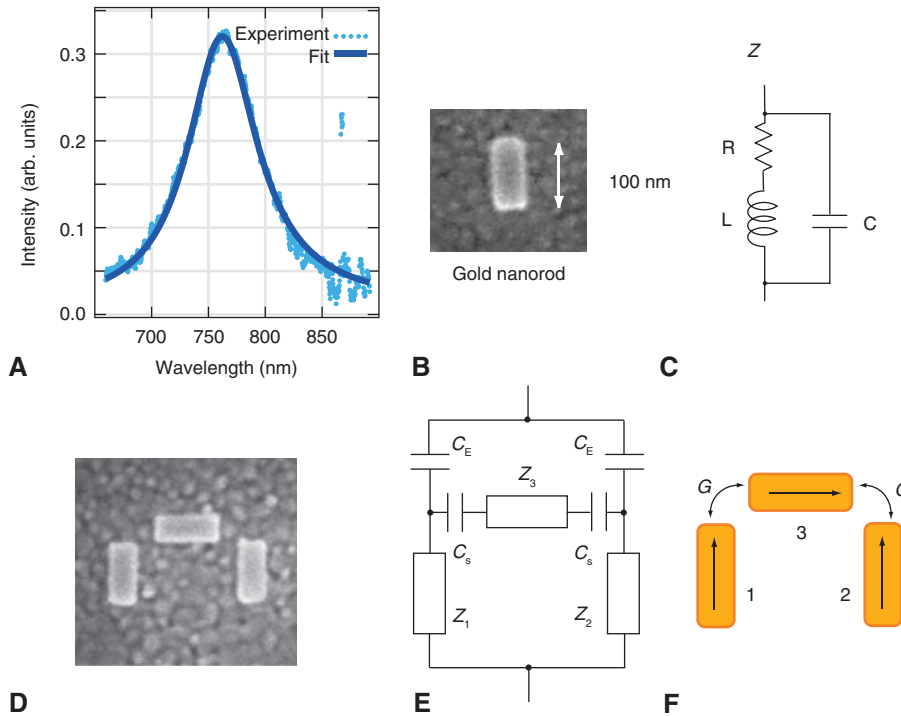

**Figure 6:** Plasmonics as electronics. (A) An example of the scattering spectrum from a single gold nanorod  $l=100$  nm,  $w=40$  nm,  $t=30$  nm; (B) SEM image of the resist used to define a gold nanorod during lithography; (C) the equivalent circuit impedance of the rod – the spectrum is fit to  $I=A+B|Z|^2$  where  $Z=(R+j\omega L)/(1-\omega^2 LC+j\omega RC)$  is the circuit impedance. The fit gives the lumped component values  $RC=3.99 \times 10^{-17}$  s and  $LC=1.64 \times 10^{-31}$  s<sup>2</sup> and the resonant frequency is  $f=1/2\pi\sqrt{LC}=393$  THz; (D) a three-nanorod structure that mimics a Wheatstone bridge circuit [150, 151]; (E) the equivalent electrical circuit; (F) an alternative analysis using plasmon coupling theory [152] that gives plasmon excitation amplitude on nanorod 3  $\tilde{a}_3=[Gp \cdot (E_1 - E_2)]/[(\delta\omega + i\Gamma/2)^2 - 2G^2]$  directly in terms of parameters associated with the optics of nanoparticles – the detuning  $\delta\omega$  from the single rod resonance of FWHM  $\Gamma$ , dipole moment  $p$  and interparticle coupling  $G$ . The LSP amplitude depends on the difference in the electric fields  $E_1 - E_2$  of the light incident on the two parallel rods, 1 and 2.

Engheta et al. [153, 154] in terms of the electric permittivities and independently by Davis [155] in terms of lumped circuit elements determined from considerations of power flow. This same procedure was used more recently to extract lumped values from complicated arrangements of particles [156]. In essence, a metal particle supporting LSPs can be represented by a combination of inductance, capacitance, and resistance (Figure 6B). The inductance is a consequence of the negative electric permittivity of metals at optical frequencies [154]. The capacitance is related to the influence of the surrounding dielectric, and resistance arises from loss in the metal when a current flows or when the plasmon re-radiates light (radiation resistance). Similarly, a dielectric particle acts like a capacitor [154]. Formulae that accurately predict the circuit values for arbitrary-shaped plasmonic structures are not available. For a metal sphere of radius  $R$  and complex permittivity  $\epsilon_m = \epsilon'_m + i\epsilon''_m$ , the equivalent inductance is given approximately by  $L_{\text{sph}} \approx -1/(\omega^2 \pi R \epsilon'_m)$ , which depends on the real part of the permittivity. The capacitance associated with the external electric fields  $C_{\text{fringe}} \approx 2\pi\omega R \epsilon_0$  depends on the

permittivity of the surrounding space. The resistance of the sphere depends on the imaginary part  $\epsilon''_m$  of the permittivity [154].

The plasmon circuit model provides a means for designing optical elements using LSPs in the same way one would design an electrical circuit (Figure 6). This is a radical departure from the usual interpretation of plasmonics as an optical phenomenon and creates new ways of approaching optical information manipulation. The proximity of one metal nanoparticle to another leads to capacitive coupling between the LSPs, mediated by their electric fields. This can result in quite complex circuits and circuit models [156]. The coupling between plasmonic particles is interesting because the resonant modes are altered and generally form pairs that are split in frequency. Such behavior is a consequence of coupled oscillators, well known in physics and engineering. In the study of LSPs, the mode splitting has been described in terms of the hybridization of molecular orbitals that occurs when two atoms bind, which leads to bonding and anti-bonding states [157–159].

The lumped circuit values for plasmonic circuits are generally unknown, and the circuit element associated with a given interaction has to be assumed. Unlike conventional electronics, the inductance of plasmonic particles is strongly dependent on frequency. Furthermore, the role of light polarization on circuit elements is unclear. We developed, as an alternative, an approach based on approximate solutions of Maxwell's equations for the interaction of electromagnetic waves with metal particles. It is possible to write down an equation for the natural resonant modes of an arbitrary shaped metal particle, which becomes relatively simple in the near-field regime where the phase shifts due to propagation of the electromagnetic radiation can be neglected [160–162]. These resonant modes are the LSPs (Figure 2D and E) and are represented by surface charge standing waves. The electric fields from the surface charges couple nearby particles, predominantly through electric dipole interactions. When the coupling between the modes is taken into account, one can derive a simple algebra describing the effects of ensembles of metal nanostructures on one another and on the incident and scattered light fields [152, 163–165]. This is quite analogous to the description in terms of electrical circuits and leads to algebraic expressions no more complicated than those found in electric circuit analysis. The advantage is the algebra is expressed in terms of the natural quantities associated with LSPs, such as electric permittivity, induced dipole moments, and coupling by electric fields including the polarization properties of the incident light fields. This algebraic approach has been very successful and has enabled us to design quite complex circuits, such as the plasmonic Wheatstone bridge that can be used for phase detection [150, 151], all-optical modulation and switching [166], as well as antennas with frequency-dependent beaming [167] and response tailored to the handedness of circular polarization [168].

## 4.1 Optical antennas

Alongside the development of plasmonic systems as electrical circuits, it has been recognized that metal nanoparticles behave like antennas for light [169, 170]. The optical cross section of a metal nanoparticle is significantly larger than its physical cross section, meaning that a small nano-sized particle can capture light over a much larger area and convert it into a localized plasmon resonance. The simplest optical antenna is a metal nanorod. The fundamental plasmon resonance has a large dipole moment (Figure 2D), and it acts like a half-wave antenna. However, the wavelength corresponds to that of the plasmon and

not the incident light, so that optical antennas can have dimensions well below the wavelength of light. Furthermore, the fundamental mode can only be excited by light with an electric field component parallel to the dipole moment, which usually lies along the major axis of the rod, making these optical antennas polarization sensitive. The LSP resonance stores optical energy and, as such, develops very strong electric fields concentrated at the ends of the rod, at least an order of magnitude larger than the electric field of the incident light that excites it. The localization of energy provides efficient coupling of optical energy into other systems, such as waveguides and fluorescent molecules [171, 172], and likewise, the plasmonic antenna can efficiently out-couple radiation from molecules, enhancing emission and polarization characteristics. The quality factor ( $Q$ ) of the resonance depends on the metal and the dielectric environment but is typically in the range  $Q \sim 10$ – $20$ .

There has been a large variety of antenna configurations investigated, many of which are based on designs used in radio engineering. As light is an electromagnetic wave, most of the concepts of radio antenna design carry across to the optical domain, except that the conductors are not perfect but are lossy. Optical antennas have been reviewed extensively elsewhere [169, 170, 173], and we give only a brief overview here. Although much has been written on optical antennas, these are essentially metal particles exhibiting LSP resonances and it is more useful to describe them as such. Most optical antenna designs are dipole antennas, even though the antenna geometry can be complicated, as the fundamental resonant mode is predominantly dipolar in nature. Initial studies on optical antennas verified the field enhancement properties of plasmons [174] and the spectral dependence of the antenna near-field [175]. Optical antennas have been used to enhance optical coupling into materials [176], plasmonic waveguides, and transmission lines [177–179]. Examples of different optical antenna designs are the Yagi-Uda antenna [180, 181], cross antennas [182], J-pole [183, 184], V antennas [183], and bow-tie antennas [185]. As with radio engineering, it is possible to create antenna arrays [173] for controlling the divergence and radiation direction of a light beam [186, 187] and plasmonic structures for steering the radiation direction of light depending on frequency [167] or controlling the propagation direction of plasmons based on phase [188]. The antenna excitation patterns [189, 190] can be altered by changing the phase and polarization of the incident light, which affects the plasmon modes that are excited [191].

The antennas can have a strong influence on the optical emission properties of fluorescent molecules

[192, 193], leading to enhanced, polarized, and directed emission, which can be described in terms of impedance matching [194]. Furthermore, such plasmonic antennas can be used to convert polarization states from linear to circular [195] or to distinguish between left and right circularly polarized light [168]. In this regard, a self-consistent electromagnetic theory of the coupling between dipole emitters and dissipative nanoresonators has been developed [63]. The antenna response can be modified by placing dielectric materials or other metals nearby, which affect the LSP resonances. This is analogous to capacitive and inductive loading of the antenna [196, 197]. When loaded with non-linear materials, it has been shown theoretically that optical antennas can exhibit bistability [198]. Tunable plasmonic antennas were created from two suspended wires and changing their separation with an applied voltage [199].

## 4.2 Plasmonic circuits

There has been relatively little work relating plasmonics to electronics and building devices using this concept. The concepts of distributed electronic circuit components have been applied to optical structures such as transmission lines [153, 200], and an analysis of the optical power associated with electromagnetic waves can be related to lumped circuit components [155, 156, 201]. The lumped circuit description has been demonstrated in the optical regime (below 700 nm) in terms of an inductor-capacitor circuit [155] in the thermal infrared regime (8–14  $\mu\text{m}$ ) [202] and mid infrared (above 1.3  $\mu\text{m}$ ) [203].

Simple plasmonic circuits have been shown to act as filters for waveguides [204] or for loading antennas [196, 197], as well as mimicking more complex filters, such as a third-order Butterworth filter [205]. The correspondence between metal and dielectric particles and electronic components has been demonstrated using a scanning probe tip to assemble together different optical filter combinations [206]. That the optical resonances of metal nanoparticles can be altered in the presence of other metals or dielectrics is well known so it is not surprising that optical filters can be created in this way.

There are very few complex plasmonic circuits demonstrated with specific functionality. The plasmonic equivalent of the Wheatstone bridge circuit in electronics was suggested as a means for detecting optical signal differences [150], and a realization of the circuit with dimensions around 200 nm acts as an optical differentiator to detect optical phase differences [151]. Circuits of this type have potential applications in optical signal processing,

such as decoders for differential phase-shift keying. The plasmon coupling theory [152, 163, 164] shows that such plasmonic circuits output signals that are linear combinations of the inputs  $E_{\text{out}} = \bar{M} \cdot E_{\text{in}}$ , but with complex matrix coefficients  $\bar{M}$  [166], which suggests that a variety of different linear mathematical operations can be performed. This plasmon circuit concept was used to design a device for all-optical modulation of light, based on an interference effect, as well as all-optical switching of light beams [166].

The idea of performing mathematical operations on light fields using nanoscale structures was highlighted recently where optical Fourier transforms were demonstrated numerically [207]. In addition to the optical differentiator described above [151], designs for an optical differentiator and integrator were demonstrated [208], providing an approach to analogue optical computing.

## 5 Quantum plasmonics

Although plasmon properties can be described by classical electromagnetism, the plasmons arise from long-range correlations of the conduction band electrons in a metal and appear in the form of quasi-particle boson states with both particle and wave-like properties. In particular, the plasmons remain coherent with the incident light, suggesting that it should be possible to observe quantum coherence effects with them or to use plasmons for manipulating quantum properties of light. The resurgence of interest in plasmonics has been accompanied by an interest in their quantum properties [59, 209], which includes coherence, entanglement, and wave-particle duality [209]. Plasmon waveguides have been used to observe quantum interference [65] as well as two plasmon quantum interference [210]. The wave-particle duality of single SPPs has been studied using single photon emitters coupled to a silver plasmon waveguide [57]. The quantum tunneling of electrons across sub-nanometer gaps between coupled plasmonic particles has been investigated [211]. Plasmons also couple to quantum systems, such as semiconductor nanocrystals [212, 213]. The strong coupling between individual optical emitters and propagating surface plasmons has been proposed as an interface for quantum networks [214].

## 6 New materials

A major issue with both classical and quantum plasmonic devices is loss due to electron decoherence, which is

followed by absorption of energy in the metal lattice. This destroys the coherence of the plasmon quantum state. This problem of energy loss in the metal also limits the use of plasmonic devices in telecommunications, which often demands low loss materials and low insertion loss. While active media or stimulated emission [43, 53] may overcome losses, an alternative has been to seek low loss materials that support plasmon resonances [215]. The key material property required for plasmonic behavior is an electric permittivity that is negative over a range of frequencies. A review of work on new materials [216] discusses the advantages and disadvantages of various metals and semiconductors with the conclusion that silver, gold, and aluminum are still the best materials for SPPs and LSP resonances in the visible and ultraviolet regions. Recently, titanium nitride was identified as a promising material for the visible and near infrared regions [217] although it has a smaller electric permittivity and greater losses when compared with gold at the same frequency. In this regard, gold is a better material for plasmonics.

## 7 Outlook

Despite the initial promise of plasmonics for nanoscale optical devices, there are disappointingly few commercial applications of plasmonics and none in the communications field [218, 219]. Most of the devices presented in this review have scientific interest, but few are practical solutions to photonics problems. Certainly, for plasmonics to have some future in optical signal processing, it is important that methods and materials are developed for better integration with existing communications technology. In this regard, devices such as the all-plasmonic Mach-Zehnder modulator that was constructed on a silicon chip show promise [139].

For optical signal processing or optical computing based on plasmonics, logic and computational operations need to be developed using current encoding schemes instead of just phase. With the advantage of far lower losses than metals, dielectrics are likely to play an increasing role in all-optical processing. Recent developments in silicon technology for the telecommunications wavelengths are now competing with plasmonic devices. These on-chip silicon devices, such as a wavelength demultiplexer and a polarization beamsplitter, have small footprints and are composed entirely of dielectrics [220]. However, plasmonic devices, with smaller resonator sizes, subwavelength size scales, and potential for compatibility with conventional CMOS processing techniques, may

still have an important place in this emerging and exciting field.

**Acknowledgment:** This work was funded in part through the Australian Research Council Discovery Grant DP160100983. D.G. also acknowledges ARC funding FT140100514.

## References

- [1] Ambs P. Optical computing: a 60-year adventure. *Adv Opt Technol* 2010;2010:1–15.
- [2] Athale R, Psaltis D. Optical computing: past and future. *Optics Photonics News* June 2016;27:32–9.
- [3] Touch J, Willner AE. Native digital processing for optical networking. In: *Third International Conference on Future Generation Communication Technologies (FGCT 2014)*, Luton, 2014, pp. 14–18. doi: 10.1109/FGCT.2014.6933232.
- [4] Kirkpatrick K. Software-defined networking. *Commun ACM* 2013;56:16–9.
- [5] Kreutz D, Ramos FMV, VerÄssimo PE, Rothenberg CE, Azodolmoly S, Uhlig S. Software-defined networking: a comprehensive survey. *Proc IEEE* 2015;103:14–76.
- [6] Davis TJ. Plasmonics: the convergence between optics and electronics. In: *Proc. SPIE 8923, Micro/Nano Materials, Devices, and Systems, 89232R*, December 7, 2013. doi: 10.1117/12.2044696.
- [7] Tucker RS. The role of optics in computing. *Nat Photon* 2010;4:405.
- [8] Maier SA. *Plasmonics: Fundamentals and Applications*. USA, Springer, 2007.
- [9] Raether H. Surface plasma oscillations and their applications. In: *Hass G, Francombe MH, Hoffman RW, editors, Physics of Thin Films*. New York, USA, Academic Press, 1977;9:145–261.
- [10] Oulton R, Sorger V, Genov D, Pile D, Zhang X. A hybrid plasmonic waveguide for subwavelength confinement and long-range propagation. *Nat Photon* 2008;2:496–500.
- [11] Ozbay E. Plasmonics: merging photonics and electronics at nanoscale dimensions. *Science* 2006;311:189–93.
- [12] Sohler W, De La Rue R. Integrated optics – from single photon sources to complex photonic circuits. *Laser Photonics Rev* 2012;6:A5–6.
- [13] Barnes W, Dereux A, Ebbesen T. Surface plasmon subwavelength optics. *Nature* 2003;424:824–30.
- [14] Han Z, Bozhevolnyi SI. Radiation guiding with surface plasmon polaritons. *Rep Prog Phys* 2013;76:016402.
- [15] Maier S, Atwater H. Plasmonics: localization and guiding of electromagnetic energy in metal/dielectric structures. *J Appl Phys* 2005;98:011101.
- [16] Polman A, Atwater H. Plasmonics: optics at the nanoscale. *Mater Today* 2005;8:56.
- [17] Smith CLC, Stenger N, Kristensen A, Mortensen NA, Bozhevolnyi SI. Gap and channelled plasmons in tapered grooves: a review. *Nanoscale* 2015;7:9355–86.
- [18] Sorger VJ, Oulton RF, Ma R, Zhang X. Toward integrated plasmonic circuits. *MRS Bull* 2012;37:728–38.

- [19] Stockman M. Nanoplasmonics: past, present, and glimpse into future. *Opt Express* 2011;19:22029–106.
- [20] Zayats A, Smolyaninov I, Maradudin A. Nano-optics of surface plasmon polaritons. *Phys Rep* 2005;408:131–314.
- [21] Bouhelier A, Huser T, Tamaru H, et al. Plasmon optics of structured silver films. *Phys Rev B* 2001;63:155404.
- [22] Davis T. Surface plasmon modes in multi-layer thin-films. *Opt Commun* 2009;282:135–40.
- [23] Willets KA, Duyn RPV. Localized surface plasmon resonance spectroscopy and sensing. *Annu Rev Phys Chem* 2007;58:267–7.
- [24] Davis T, Gómez D, Vernon K. Simple model for the hybridization of surface plasmon resonances in metallic nanoparticles. *Nano Lett* 2010;10:2618–25.
- [25] Kou SS, Yuan G, Wang Q, et al. On-chip photonic fourier transform with surface plasmon polaritons. *Light Sci Appl* 2016;5:e16034.
- [26] Lu C, Hu X, Yang H, Gong Q. All-optical logic binary encoder based on asymmetric plasmonic nanogrooves. *Appl Phys Lett* 2013;103:121107.
- [27] Lu C, Hu X, Yang H, Gong Q. Integrated all-optical logic discriminators based on plasmonic bandgap engineering. *Sci Rep* 2013;3:2778.
- [28] Lu C, Liu Y, Hu X, Yang H, Gong Q. Integrated ultracompact and broadband wavelength demultiplexer based on multi-component nano-cavities. *Sci Rep* 2016;6:27428.
- [29] Devaux E, Ebbesen T, Weeber J, Dereux A. Launching and decoupling surface plasmons via micro-gratings. *Appl Phys Lett* 2003;83:4936–8.
- [30] Bozhevolnyi SI, Volkov VS, Devaux E, Laluet J, Ebbesen TW. Channel plasmon subwavelength waveguide components including interferometers and ring resonators. *Nature* 2006;440:508–11.
- [31] Brongersma M, Zia R, Schuller J. Plasmonics – the missing link between nanoelectronics and microphotonics. *Appl Phys A* 2007;89:221–3.
- [32] Gramotnev D, Bozhevolnyi S. Plasmonics beyond the diffraction limit. *Nat Photon* 2010;4:83–91.
- [33] Berini P. Plasmon-polariton waves guided by thin lossy metal films of finite width: bound modes of symmetric structures. *Phys Rev B* 2000;61:10484–503.
- [34] Berini P. Plasmon-polariton waves guided by thin lossy metal films of finite width: bound modes of asymmetric structures. *Phys Rev B* 2001;63:1254171–15.
- [35] Berini P, Charbonneau R, Lahoud N, Mattiussi G. Characterization of long-range surface-plasmon-polariton waveguides. *J Appl Phys* 2005;98:043109.
- [36] Park S, Kim M, Kim J, Park S, Ju J, Lee M. Long range surface plasmon polariton waveguides at 1.31 and 1.55  $\mu\text{m}$  wavelengths. *Opt Commun* 2008;281:2057–61.
- [37] Guasoni M, Conforti M, De Angelis C. Light propagation in nonuniform plasmonic subwavelength waveguide arrays. *Opt Commun* 2010;283:1161–8.
- [38] Barrow SJ, Funston AM, Gómez DE, Davis TJ, Mulvaney P. Surface plasmon resonances in strongly coupled gold nanosphere chains from monomer to hexamer. *Nano Lett* 2011;11:4180–7.
- [39] Maier SA, Kik P, Atwater H, et al. Local detection of electromagnetic energy transport below the diffraction limit in metal nanoparticle plasmon waveguides. *Nat Mater* 2003;2:229.
- [40] Markel V, Sarychev A. Propagation of surface plasmons in ordered and disordered chains of metal nanospheres. *Phys Rev B* 2007;75:085426.
- [41] Sukharev M, Seideman T. Phase and polarization control as a route to plasmonic nanodevices. *Nano Lett* 2006;6:715–9.
- [42] Boltasseva A, Volkov VS, Nielsen RB, Moreno E, Rodrigo SG, Bozhevolnyi SI. Triangular metal wedges for subwavelength plasmon-polariton guiding at telecom wavelengths. *Opt Express* 2008;16:5252–60.
- [43] Bergman DJ, Stockman MI. Surface plasmon amplification by stimulated emission of radiation: quantum generation of coherent surface plasmons in nanosystems. *Phys Rev Lett* Jan 2003;90:027402.
- [44] Bolger PM. Amplified spontaneous emission of surface plasmon polaritons and limitations on the increase of their propagation length. *Opt Lett* 2010;35:1197–9.
- [45] Khurgin JB, Sun G. Practicality of compensating the loss in the plasmonic waveguides using semiconductor gain medium. *Appl Phys Lett* 2012;100:011105.
- [46] Noginov MA, Podolskiy VA, Zhu G, et al. Compensation of loss in propagating surface plasmon polariton by gain in adjacent dielectric medium. *Opt Express* 2008;16:1385–92.
- [47] Stockman MI. Spaser action, loss compensation, and stability in plasmonic systems with gain. *Phys Rev Lett* 2011;106:156802.
- [48] Pile D, Ogawa T, Gramotnev D, et al. Two-dimensionally localized modes of a nanoscale gap plasmon waveguide. *Appl Phys Lett* 2005;87:1–4.
- [49] Moreno E, Garcia-Vidal FJ, Rodrigo SG, Martín-Moreno L, Bozhevolnyi SI. Channel plasmon-polaritons: modal shape, dispersion, and losses. *Opt Lett* Dec 2006;31:3447–9.
- [50] Moreno E, Rodrigo SG, Bozhevolnyi SI, Martín-Moreno L, García-Vidal FJ. Guiding and focusing of electromagnetic fields with wedge plasmon polaritons. *Phys Rev Lett* 2008;100:023901.
- [51] Huang K, Seo M, Sarmiento T, Huo Y, Harris J, Brongersma M. Electrically driven subwavelength optical nanocircuits. *Nat Photon* 2014;8:244–9.
- [52] Stockman M. Spasers explained. *Nat Photon* 2008;2:327–9.
- [53] Noginov M, Zhu G, Belgrave A, et al. Demonstration of a spaser-based nanolaser. *Nature* 2009;460:1110–2.
- [54] Akimov AV, Mukherjee A, Yu CL, et al. Generation of single optical plasmons in metallic nanowires coupled to quantum dots. *Nature* 2007;450:402–6.
- [55] Fedutik Y, Temnov VV, Schops O, Woggon U, Artemyev MV. Exciton-plasmon-photon conversion in plasmonic nanostructures. *Phys Rev Lett* 2007;99:136802.
- [56] Fedutik Y, Temnov VV, Woggon U, Ustinovich E, Artemyev MV. Exciton-plasmon interaction in a composite metal-insulator-semiconductor nanowire system. *J Am Chem Soc* 2007;129:14939–45.
- [57] Kolesov R, Grotz B, Balasubramanian G, et al. Wave-particle duality of single surface plasmon polaritons. *Nat Phys* 2009;5:470–4.
- [58] Tame MS, Lee C, Lee J, et al. Single-photon excitation of surface plasmon polaritons. *Phys Rev Lett* 2008;101:190504.
- [59] de Leon NP, Lukin MD, Park H. Quantum plasmonic circuits. *IEEE J Sel Top Quant* 2012;18:1781–91.
- [60] Popov O, Lirtsman V, Davidov D. Surface plasmon excitation of amplified spontaneous emission from laser dye molecules embedded in polymer matrix. *Appl Phys Lett* 2009;95:191108–3.

- [61] Gather M, Meerholz K, Danz N, Leosson K. Net optical gain in a plasmonic waveguide embedded in a fluorescent polymer. *Nat Photon* 2010;4:457–61.
- [62] Shen J. Dispersion-sensitive surface plasmon wave assisted by incoherent gain. *Opt Commun* 2014;329:15–22.
- [63] Sauvan C, Hugonin J, Maksymov I, Lalanne P. Theory of the spontaneous optical emission of nanosize photonic and plasmon resonators. *Phys Rev Lett* 2013;110:237401.
- [64] Akbari A, Berini P. Schottky contact surface-plasmon detector integrated with an asymmetric metal stripe waveguide. *Appl Phys Lett* 2009;95:021104.
- [65] Heeres R, Kouwenhoven L, Zwiller V. Quantum interference in plasmonic circuits. *Nat Nanotechnol* 2013;8:719–22.
- [66] Rosenberg J, Shenoi R, Vandervelde T, Krishna S, Painter O. A multispectral and polarization-selective surface-plasmon resonant midinfrared detector. *Appl Phys Lett* 2009;95:161101–3.
- [67] Knight M, Sobhani H, Nordlander P, Halas N. Photodetection with active optical antennas. *Science* 2011;332:702–4.
- [68] Bian Y, Gong Q. Compact all-optical interferometric logic gates based on one-dimensional metal–insulator–metal structures. *Opt Commun* 2014;313:27–35.
- [69] Bozhevolnyi S, Volkov V, Devaux E, Laluet J, Ebbesen T. Channeling surface plasmons. *Appl Phys A* 2007;89:225–31.
- [70] Cai W, Shin W, Fan S, Brongersma M. Elements for plasmonic nanocircuits with three-dimensional slot waveguides. *Adv Mater* 2010;22:5120–4.
- [71] Li Z, Zhang S, Halas N, Nordlander P, Xu H. Coherent modulation of propagating plasmons in silver-nanowire-based structures. *Small* 2011;7:593–6.
- [72] Pourali E, Baboli MA. Design and analysis of an all optical or gate using surface plasmon hopping along metallic nanorods. *Physica Scripta* 2015;90:045501.
- [73] Han Z, Liu L, Forsberg E. Ultra-compact directional couplers and mach-zehnder interferometers employing surface plasmon polaritons. *Opt Commun* 2006;259:690–5.
- [74] Zenin V, Volkov V, Han Z, Bozhevolnyi S, Devaux E, Ebbesen T. Directional coupling in channel plasmon-polariton waveguides. *Opt Express* 2012;20:6124–34.
- [75] Charbonneau R, Lahoud N, Mattiussi G, Berini P. Demonstration of integrated optics elements based on long-ranging surface plasmon polaritons. *Opt Express* 2005;13:977–84.
- [76] Charbonneau R, Tencer M, Lahoud N, Berini P. Demonstration of surface sensing using long-range surface plasmon waveguides on silica. *Sensor Actuat B Chem* 2008;134:455–61.
- [77] Perera C, Vernon K, Cheng E, Sathian J, Jaatinen E, Davis T. Highly compact refractive index sensor based on stripe waveguides for lab-on-a-chip sensing applications. *Beilstein J Nanotechnol* 2016;7:751–7.
- [78] Vernon K, Gómez D, Davis T. A compact interferometric sensor design using three waveguide coupling. *J Appl Phys* 2009;106:104306.
- [79] Volkov V, Bozhevolnyi S, Devaux E, Laluet J, Ebbesen T. Wavelength selective nanophotonic components utilizing channel plasmon polaritons. *Nano Lett* 2007;7:880–4.
- [80] Bozhevolnyi S, Boltasseva A, S ndergaard T, Nikolajsen T, Leosson K. Photonic bandgap structures for long-range surface plasmon polaritons. *Opt Commun* 2005;250:328–33.
- [81] Wu W, Yang J, Zhang J, Huang J, Chen D, Wang H. Ultra-high resolution filter and optical field modulator based on a surface plasmon polariton. *Opt Lett* 2016;41:2310–3.
- [82] Liu Y, Kim J. Plasmonic modulation and switching via combined utilization of young interference and metal-insulator-metal waveguide coupling. *J Opt Soc Am B* 2011;28:2712–7.
- [83] Dickson R, Lyon L. Unidirectional plasmon propagation in metallic nanowires. *J Phys Chem B* 2000;104:6095–8.
- [84] Chen Z, Chen J, Li Y, et al. Simulation of nanoscale multifunctional interferometric logic gates based on coupled metal gap waveguides. *IEEE Photonic Tech L* 2012;24:1366–8.
- [85] Dolatabady A, Granpayeh N. All optical logic gates based on two dimensional plasmonic waveguides with nanodisk resonators. *J Opt Soc Korea* 2012;16:432–42.
- [86] Tuccio S, Centini M, Benedetti A, Sibilia C. Subwavelength coherent control and coupling of light in plasmonic nanoresonators on dielectric waveguides. *J Opt Soc Am B* 2013;30:450–5.
- [87] Wang F, Gong Z, Hu X, Yang X, Yang H, Gong Q. Nanoscale on-chip all-optical logic parity checker in integrated plasmonic circuits in optical communication range. *Sci Rep* 2016;6:24433.
- [88] Wen J, Chen J, Wang K, Dai B, Huang Y, Zhang D. Broadband plasmonic logic input sources constructed with dual square ring resonators and dual waveguides. *IEEE Photonics J* 2016;8:1–9.
- [89] Zhao H, Guang X, Huang J. Novel optical directional coupler based on surface plasmon polaritons. *Physica E* 2008;40:3025–9.
- [90] Zhou X, Fu Y, Li K, Wang S, Cai Z. Coupling mode-based nanophotonic circuit device. *Appl Phys B* 2008;91:373–6.
- [91] Wei H, Wang Z, Tian X, Kall M, Xu H. Cascaded logic gates in nanophotonic plasmon networks. *Nat Commun* 2011;2:387.
- [92] Fu Y, Hu X, Lu C, Yue S, Yang H, Gong Q. All-optical logic gates based on nanoscale plasmonic slot waveguides. *Nano Lett* 2012;12:5784–90.
- [93] Cohen M, Zalevsky Z, Shavit R. Towards integrated nanoplasmonic logic circuitry. *Nanoscale* 2013;5:5442–9.
- [94] Lu C, Hu X, Yue S, Fu Y, Yang H, Gong Q. Ferroelectric hybrid plasmonic waveguide for all-optical logic gate applications. *Plasmonics* 2013;8:749–54.
- [95] Lu C, Hu X, Yang H, Gong Q. Chip-integrated ultrawide-band all-optical logic comparator in plasmonic circuits. *Sci Rep* 2014;4:3869.
- [96] Birr T, Zywiets U, Chhantyal P, Chichkov B, Reinhardt C. Ultrafast surface plasmon-polariton logic gates and half-adder. *Opt Express* 2015;23:31755–65.
- [97] Ota M, Sumimura A, Fukuhara M, Ishii Y, Fukuda M. Plasmonic-multimode-interference-based logic circuit with simple phase adjustment. *Sci Rep* 2016;6:24546.
- [98] Yan Y, Zhang C, Zheng J, Yao J, Zhao Y. Optical modulation based on direct photon-plasmon coupling in organic/metal nanowire heterojunctions. *Adv Mater* 2012;24:5681–6.
- [99] Perera CS, Vernon KC, Funston AM, Cheng H, Eftekhari F, Davis TJ. Excitation of bound plasmons along nanoscale stripe waveguides: a comparison of end and grating coupling techniques. *Opt Express* 2015;23:10188–97.
- [100] Kauranen M, Zayats A. Nonlinear plasmonics. *Nat Photon* 2012;6:737–48.
- [101] MacDonald K, Zheludev N. Active plasmonics: current status. *Laser Photonics Rev* 2010;4:562–7.
- [102] Ooi K, Chu H, Bai P, Ang L. Electro-optical graphene plasmonic logic gates. *Opt Lett* 2014;39:1629–32.

- [103] Margheri G, Rosso TD, Sottini S, Trigari S, Giorgetti E. All optical switches based on the coupling of surface plasmon polaritons. *Opt Express* 2008;16:9869–83.
- [104] Nozhat N, Granpayeh N. All-optical logic gates based on nonlinear plasmonic ring resonators. *Appl Opt* 2015;54:7944–8.
- [105] Shiu R, Lan Y, Guo G. Optical multiple bistability in metal-insulator-metal plasmonic waveguides side-coupled with twin racetrack resonators. *J Opt Soc Am B* 2014;31:2581–6.
- [106] Zhang W, Jiang Y, Zhu Y, Wang F, Rao Y. All-optical bistable logic control based on coupled tamm plasmons. *Opt Lett* 2013;38:4092–5.
- [107] Zhao W, Ju D, Jiang Y. Pulse controlled all-optical logic gate based on nonlinear ring resonator realizing all fundamental logic operations. *Plasmonics* 2015;10:311–7.
- [108] Gogoi N, Sahu P. All-optical compact surface plasmonic two-mode interference device for optical logic gate operation. *Appl Opt* 2015;54:1051–7.
- [109] Dai J, Zhang M, Zhou F, Wang Y, Lu L, Liu D. All-optical logic operation of polarized light signals in highly nonlinear silicon hybrid plasmonic microring resonators. *Appl Opt* 2015;54:4471–7.
- [110] Wang L, Yan L, Guo Y, Wen K, Pan W, Luo B. Optical quasi logic gates based on polarization-dependent four-wave mixing in subwavelength metallic waveguides. *Opt Express* 2013;21:14442–51.
- [111] Shen Y, Wang GP. Optical bistability in metal gap waveguide nanocavities. *Opt Express* 2008;16:8421–6.
- [112] Cai W, White J, Brongersma M. Compact, high-speed and power-efficient electrooptic plasmonic modulators. *Nano Lett* 2009;9:4403–11.
- [113] Battal E, Okyay AK. Metal-dielectric-metal plasmonic resonators for active beam steering in the infrared. *Opt Lett* 2013;38:983–5.
- [114] Kim H, Park J, Lee B. Tunable directional beaming from subwavelength metal slits with metal-dielectric composite surface gratings. *Opt Lett* 2009;34:2569–71.
- [115] Krasavin A, Zayats A. Photonic signal processing on electronic scales: electro-optical field-effect nanoplasmonic modulator. *Phys Rev Lett* 2012;109:053901.
- [116] Piao X, Yu S, Park N. Control of fano asymmetry in plasmon induced transparency and its application to plasmonic waveguide modulator. *Opt Express* 2012;20:18994–9.
- [117] Ding C, Hu X, Jiang P, Gong Q. Tunable surface plasmon polariton microcavity. *Phys Lett A* 2008;372:4536–8.
- [118] Chang D, Sorensen A, Demler E, Lukin M. A single-photon transistor using nanoscale surface plasmons. *Nat Phys* 2007;3:807–12.
- [119] Tao J, Huang X, Chen J, Zhu J. All-optical broadband variable optical attenuators and switches in plasmonic teeth waveguides. *Opt Commun* 2010;283:3536–9.
- [120] Lee Y, Hoshino K, Alù A, Zhang X. Tunable directive radiation of surface-plasmon diffraction gratings. *Opt Express* 2013;21:2748–56.
- [121] Eggleton BJ, Luther-Davies B, Richardson K. Chalcogenide photonics. *Nat Photon* 2011;5:141–8.
- [122] Krasavin A, Vo T, Dickson W, Bolger P, Zayats A. All-plasmonic modulation via stimulated emission of copropagating surface plasmon polaritons on a substrate with gain. *Nano Lett* 2011;11:2231–5.
- [123] Pacifici D, Lezec H, Atwater H. All-optical modulation by plasmonic excitation of cdse quantum dots. *Nat Photon* 2007;1:402–6.
- [124] Ming T, Zhao L, Xiao M, Wang J. Resonance-coupling-based plasmonic switches. *Small* 2010;6:2514–9.
- [125] Caspers J, Rotenberg N, van Driel HM. Ultrafast silicon-based active plasmonics at telecom wavelengths. *Opt. Express* 2010;18:19761–9.
- [126] Cho D, Wu W, Ponizovskaya E, et al. Ultrafast modulation of optical metamaterials. *Opt Express* 2009;17:17652–7.
- [127] Macdonald K, Sámson L, Stockman M, Zheludev N. Ultrafast active plasmonics. *Nat Photon* 2009;3:55–8.
- [128] Ren M, Jia B, Ou J, et al. Nanostructured plasmonic medium for terahertz bandwidth all-optical switching. *Adv Mater* 2011;23:5540–4.
- [129] Guo P, Schaller R, Ketterson J, Chang R. Ultrafast switching of tunable infrared plasmons in indium tin oxide nanorod arrays with large absolute amplitude. *Nat Photon* 2016;10:267–73.
- [130] Abb M, Albella P, Aizpurua J, Muskens O. All-optical control of a single plasmonic nanoantenna–ito hybrid. *Nano Lett* 2011;11:2457–63.
- [131] Chen H, Wang J, Yeh S, Chen C, Lin H. Modulation of surface plasmon wave by photo-induced refractive index changes of cdse quantum dots. *Appl Phys Lett* 2012;100:011102.
- [132] Chen J, Li Z, Yue S, Gong Q. Highly efficient all-optical control of surface-plasmon-polariton generation based on a compact asymmetric single slit. *Nano Lett* 2011;11:2933–7.
- [133] Sahu PP. Theoretical investigation of all optical switch based on compact surface plasmonic two mode interference coupler. *J Lightwave Technol* 2016;34:1300–5.
- [134] Temnov VV, Armeltes G, Woggon U, et al. Active magneto-plasmonics in hybrid metal-ferromagnet structures. *Nat Photon* 2010;4:107–11.
- [135] Earl S, James T, Davis T, et al. Tunable optical antennas enabled by the phase transition in vanadium dioxide. *Opt Express* 2013;21:27503–8.
- [136] Brüggemann C, Akimov A, Glavin B, et al. Modulation of a surface plasmon-polariton resonance by subterahertz diffracted coherent phonons. *Phys Rev B* 2012;86:121401.
- [137] Tominaga J, Mihalcea C, Buchel D, et al. Local plasmon photonic transistor. *Appl Phys Lett* 2001;78:2417–9.
- [138] Randhawa S, Lachèze S, Renger J, et al. Performance of electro-optical plasmonic ring resonators at telecom wavelengths. *Opt Express* 2012;20:2354–62.
- [139] Haffner C, Heni W, Fedoryshyn Y, et al. All-plasmonic mach-zehnder modulator enabling optical high-speed communication at the microscale. *Nat Photon* 2015;9:525–8.
- [140] Emboras A, Goykhman I, Desiatov B, et al. Nanoscale plasmonic memristor with optical readout functionality. *Nano Lett* 2013;13:6151–5.
- [141] Anglin K, Ribaudo T, Adams D, et al. Voltage-controlled active mid-infrared plasmonic devices. *J Appl Phys* 2011;109:123103.
- [142] Babicheva V, Lavrinenko A. Plasmonic modulator optimized by patterning of active layer and tuning permittivity. *Opt Commun* 2012;285:5500–7.
- [143] Dicken M, Sweatlock L, Pacifici D, Lezec H, Bhattacharya K, Atwater H. Electrooptic modulation in thin film barium titanate plasmonic interferometers. *Nano Lett* 2008;8:4048–52.
- [144] Dionne J, Diest K, Sweatlock L, Atwater H. Plasmostor: a metal-oxide-si field effect plasmonic modulator. *Nano Lett* 2009;9:897–902.

- [145] Liew T, Kavokin A, Ostatnický T, Kaliteevski M, Shelykh I, Abram R. Exciton-polariton integrated circuits. *Phys Rev B* 2010;82:033302.
- [146] Chin J, Steinle T, Wehler T, et al. Nonreciprocal plasmonics enables giant enhancement of thin-film faraday rotation. *Nature Commun* 2013;4:1599.
- [147] Papaioannou S, Kalavrouziotis D, Vyrsoinos K, et al. Active plasmonics in wdm traffic switching applications. *Sci Rep* 2012;2:652.
- [148] Agrawal A, Susut C, Stafford G, et al. An integrated electrochromic nanoplasmonic optical switch. *Nano Lett* 2011;11:2774–8.
- [149] Baba A, Tada K, Janmanee R, et al. Controlling surface plasmon optical transmission with an electrochemical switch using conducting polymer thin films. *Adv Func Mater* 2012;22:4383–8.
- [150] Davis T, Vernon K, Gómez D. A plasmonic “ac wheatstone bridge” circuit for high-sensitivity phase measurement and single-molecule detection. *J Appl Phys* 2009;106:043502.
- [151] Eftekhari F, Gómez D, Davis T. Measuring subwavelength phase differences with a plasmonic circuit: an example of nanoscale optical signal processing. *Opt Lett* 2014;39:2994–7.
- [152] Davis TJ. Evanescent coupling between resonant plasmonic nanoparticles and the design of nanoparticle systems. In: Helsey KN, editor, *Plasmons: Theory and Applications*. New York, USA, Nova Science Publishers Inc., 2011:111–41.
- [153] Engheta N. Circuits with light at nanoscales: optical nanocircuits inspired by metamaterials. *Science* 2007;317:1698–702.
- [154] Engheta N, Salandrino A, Alù A. Circuit elements at optical frequencies: nanoinductors, nanocapacitors, and nanoresistors. *Phys Rev Lett* 2005;95:95504.
- [155] Davis TJ. Modeling and fabrication of tuned circuits for optical meta-materials. In: Abbott D, Kivshar YS, Rubinsztein-Dunlop HH, Fan S, editors, *Proc. SPIE 6038, Photonics: Design, Technology, and Packaging II*, 60380Y, January 17, 2006. Bellingham, WA, USA, SPIE. doi: 10.1117/12.637871.
- [156] Abasahl B, Santschi C, Martin O. Quantitative extraction of equivalent lumped circuit elements for complex plasmonic nanostructures. *ACS Photonics* 2014;1:403–7.
- [157] Nordlander P, Oubre C, Prodan E, Li K, Stockman M. Plasmon hybridization in nanoparticle dimers. *Nano Lett* 2004;4:899–903.
- [158] Prodan E, Radloff C, Halas NJ, Nordlander P. Hybridization model for the plasmon response of complex nanostructures. *Science* 2003;302:419–22.
- [159] Wang H, Brandl DW, Nordlander P, Halas NJ. Plasmonic nanostructures: artificial molecules. *Acc Chem Res* 2007;40:53–62.
- [160] Mayergoyz ID, Zhang Z, Miano G. Analysis of dynamics of excitation and dephasing of plasmon resonance modes in nanoparticles. *Phys Rev Lett* 2007;98:147401.
- [161] Mayergoyz ID, Fredkin DR, Zhang Z. Electrostatic (plasmon) resonances in nanoparticles. *Phys Rev B* 2005;72:155412.
- [162] Ouyang F, Isaacson M. Surface plasmon excitation of objects with arbitrary shape and dielectric constant. *Phil Mag B* 1989;60:481–92.
- [163] Davis TJ, Gómez DE, Vernon KC. Simple model for the hybridization of surface plasmon resonances in metallic nanoparticles. *Nano Lett* 2010;10:2618–25.
- [164] Davis TJ, Vernon KC, Gómez DE. Designing plasmonic systems using optical coupling between nanoparticles. *Phys Rev B* 2009;79:155423.
- [165] Gómez DE, Davis TJ, Funston AM. Plasmonics by design: design principles to structure–function relationships with assemblies of metal nanoparticles. *J Mater Chem C* 2014;2:3077–87.
- [166] Davis TJ, Gómez DE, Eftekhari F. All-optical modulation and switching by a metamaterial of plasmonic circuits. *Opt Lett* 2014;39:4938–41.
- [167] Djalalian-Assl A, Gómez DE, Roberts A, Davis T. Frequency-dependent optical steering from subwavelength plasmonic structures. *Opt Lett* 2012;37:4206–8.
- [168] Eftekhari F, Davis T. Strong chiral optical response from planar arrays of subwavelength metallic structures supporting surface plasmon resonances. *Phys Rev B* 2012;86:075428.
- [169] Giannini V, Fernández-Domínguez A, Heck S, Maier S. Plasmonic nanoantennas: fundamentals and their use in controlling the radiative properties of nanoemitters. *Chem Rev* 2011;111:3888–912.
- [170] Novotny L, Niek VH. Antennas for light. *Nat Photon* 2011;5:83–90.
- [171] Davis T, Gómez DE. Interaction of localized surface plasmons with chiral molecules. *Phys Rev B* 2014;90:235424.
- [172] Davis T, Gómez D, Vernon K. Evanescent coupling between a raman-active molecule and surface plasmons in ensembles of metallic nanoparticles. *Phys Rev B* 2010;82:205434.
- [173] He S, Cui Y, Ye Y, Zhang P, Jin Y. Optical nano-antennas and metamaterials. *Materials Today* 2009;12:16–24.
- [174] Crozier K, Sundaramurthy A, Kino G, Quate C. Optical antennas: resonators for local field enhancement. *J Appl Phys* 2003;94:4632–42.
- [175] Alonso-González P, Albella P, Neubrech F, et al. Experimental verification of the spectral shift between near- and far-field peak intensities of plasmonic infrared nanoantennas. *Phys Rev Lett* 2013;110:203902.
- [176] Maksymov IS. Optical switching and logic gates with hybrid plasmonic–photonic crystal nanobeam cavities. *Phys Lett A* 2011;375:918–21.
- [177] Cohen M, Shavit R, Zalevsky Z. Enabling high efficiency nanoplasmonics with novel nanoantenna architectures. *Sci Rep* 2015;5:17562.
- [178] Geisler P, Razinskas G, Krauss E, et al. Multimode plasmon excitation and in situ analysis in top-down fabricated nanocircuits. *Phys Rev Lett* 2013;111:183901.
- [179] Huang J, Feichtner T, Biagioni P, Hecht B. Impedance matching and emission properties of nanoantennas in an optical nanocircuit. *Nano Lett* 2009;9:1897–902.
- [180] Kosako T, Kadoya Y, Hofmann HF. Directional control of light by a nano-optical yagi–uda antenna. *Nat Photon* 2010;4:312–5.
- [181] Li J, Salandrino A, Engheta N. Shaping light beams in the nanometer scale: a yagi-uda nanoantenna in the optical domain. *Phys Rev B* 2007;76:245403.
- [182] Biagioni P, Savoini M, Huang J, DuÀ L, Finazzi M, Hecht B. Near-field polarization shaping by a near-resonant plasmonic cross antenna. *Phys Rev B* 2009;80:153409.
- [183] James T, Davis T, Roberts A. Optical investigation of the j-pole and vee antenna families. *Opt Express* 2014;22:1336–41.



- [184] James T, Teo Z, Gómez D, Davis T, Roberts A. The plasmonic j-pole antenna. *Appl Phys Lett* 2013;102:033106–4.
- [185] Schuck P, Fromm D, Sundaramurthy A, Kino G, Moerner W. Improving the mismatch between light and nanoscale objects with gold bowtie nanoantennas. *Phys Rev Lett* 2005;94:174021–4.
- [186] Hao F, Zhang M, Wang Q, Wang J, Wang R, Ge H. Design and experimental demonstration of a plasmonic directional beam-ing device. *J Opt Soc Am B* 2012;29:2255–9.
- [187] Matthews D, Summers H, Njoh K, Chappell S, Errington R, Smith P. Optical antenna arrays in the visible range. *Opt Express* 2007;15:3478–87.
- [188] Dregely D, Lindfors K, Lippitz M, Engheta N, Totzeck M, Giessen H. Imaging and steering an optical wireless nanoan-tenna link. *Nat Commun* 2014;2:267–73.
- [189] Ghenuche P, Cherukulappurath S, Taminiau T, Hulst N, Quidant R. Spectroscopic mode mapping of resonant plasmon nanoantennas. *Phys Rev Lett* 2008;101:1168051–4.
- [190] Huang J, Kern J, Geisler P, et al. Mode imaging and selection in strongly coupled nanoantennas. *Nano Lett* 2010;10:2105–10.
- [191] Liu Z, Wang Y, Yao J, Lee H, Srituravanich W, Zhang X. Broad band two-dimensional manipulation of surface plasmons. *Nano Lett* 2009;9:462–6.
- [192] Hu H, Duan H, Yang J, Shen Z. Plasmon-modulated photo-luminescence of individual gold nanostructures. *ACS Nano* 2012;6:10147–55.
- [193] Taminiau T, Stefani F, Segerink F, Hulst N. Optical antennas direct single-molecule emission. *Nat Photon* 2008;2:234–7.
- [194] Greffet J, Laroche M, Marquier F. Impedance of a nano-antenna and a single quantum emitter. *Phys Rev Lett* 2010;05:117701.
- [195] Wang F, Chakrabarty A, Minkowski F, Sun K, Wei Q. Polariza-tion conversion with elliptical patch nanoantennas. *Appl Phys Lett* 2012;101:023101.
- [196] Alù A, Engheta N. Input impedance, nanocircuit loading, and radiation tuning of optical nanoantennas. *Phys Rev Lett* 2008;101:043901.
- [197] Liu N, Wen F, Zhao Y, et al. Individual nanoantennas loaded with three-dimensional optical nanocircuits. *Nano Lett* 2013;13:142–7.
- [198] Chen P, Alù A. Optical nanoantenna arrays loaded with nonlin-ear materials. *Phys Rev B* 2010;82:235405.
- [199] Chen K, Razinkas G, Feichtner T, Grossmann S, Christiansen S, Hecht B. Electromechanically tunable suspended optical nanoantenna. *Nano Lett* 2016;16:2680–5.
- [200] Alù A, Engheta N. Optical nanotransmission lines: synthesis of planar left-handed metamaterials in the infrared and visible. *J Opt Soc Am B* 2006;23:571–83.
- [201] Nunes F, Weiner J. Equivalent circuits and nanoplasmonics. *IEEE Trans Nanotechnol* 2009;8:298–302.
- [202] Sun Y, Edwards B, Alu A, Engheta N. Experimental realization of optical lumped nanocircuits at infrared wavelengths. *Nat Mater* 2012;11:208–12.
- [203] Caglayan H, Hong S, Edwards B, Kagan C, Engheta N. Near-infrared metatronic nanocircuits by design. *Phys Rev Lett* 2013;111:073904.
- [204] Lu H, Liu X, Wang G, Mao D. Tunable high-channel-count bandpass plasmonic filters based on an analogue of elec-tromagnetically induced transparency. *Nanotechnology* 2012;23:444003.
- [205] Zhang Q, Bai L, Bai Z, Hu P, Liu C. Equivalent-nanocircuit-theory-based design to infrared broad band-stop filters. *Opt Express* 2015;23:8290–7.
- [206] Shi J, Monticone F, Elias S, et al. Modular assembly of optical nanocircuits. *Nat Commun* 2014;5:3896.
- [207] Silva A, Monticone F, Castaldi G, Galdi V, Alù A, Engheta N. Performing mathematical operations with metamaterials. *Sci-ence* 2014;343:160–3.
- [208] Pors A, Nielsen M, Bozhevolnyi S. Analog computing using reflective plasmonic metasurfaces. *Nano Lett* 2015;15:791–7.
- [209] Tame MS, McEnery KR, Ozdemir SK, Lee J, Maier SA, Kim MS. Quantum plasmonics. *Nat Phys* 2013;9:329–40.
- [210] Fakonas JS, Lee H, Kelaita YA, Atwater HA. Two-plasmon quan-tum interference. *Nat Photon* 2014;8:317–20.
- [211] Zuloaga J, Prodan E, Nordlander P. Quantum description of the plasmon resonances of a nanoparticle dimer. *Nano Lett* 2009;9:887–91.
- [212] Gómez D, Roberts A, Davis T, Vernon K. Surface plas-mon hybridization and exciton coupling. *Phys Rev B* 2012;86:035411.
- [213] Gómez D, Vernon K, Mulvaney P, Davis T. Coherent superposi-tion of exciton states in quantum dots induced by surface plasmons. *Appl Phys Lett* 2010;96:073108–3.
- [214] Hong F, Xiong S. Quantum interfaces using nanoscale surface plasmons. *Eur Phys J D* 2008;50:325–9.
- [215] Boltasseva A, Atwater HA. Low-loss plasmonic metamaterials. *Science* 2011;331:290–1.
- [216] West P, Ishii S, Naik G, Emani N, Shalae V, Boltasseva A. Searching for better plasmonic materials. *Laser Photonics Rev* 2010;4:795–808.
- [217] Naik GV, Schroeder JL, Ni X, Kildishev AV, Sands TD, Boltasseva A. Titanium nitride as a plasmonic material for visible and near-infrared wavelengths. *Opt Mater Express* 2012;2:478–9.
- [218] Editorial. Commercializing plasmonics. *Nat Photon* 2015;9:477.
- [219] Krenn J. Perspective on plasmonics. *Nat Photon* 2012;6:714–5.
- [220] Aydin K. Integrated optics: nanostructured silicon success. *Nat Photon* 2015;9:353–5.